



123 NE Beacon Dr.
Grants Pass, OR 97526

GLAZED WOOD DOOR W/ SIDELITES IN SWING / OUT SWING "NON-IMPACT"

GENERAL NOTES

1. This product has been evaluated and is in compliance with the 2010 Florida Building Code (FBC) structural requirements excluding the "High Velocity Hurricane Zone" (HVHZ).
2. Product anchors shall be as listed and spaced as shown on details. Anchor embedment to base material shall be beyond wall dressing or stucco.
3. When used in areas requiring wind borne debris protection this product is required to be protected with an impact resistant covering that complies with Section 1609.1.2 of the FBC.
4. For 2x stud framing construction, anchoring of these units shall be the same as that shown for 2x buck masonry construction.
5. Site conditions that deviate from the details of this drawing require further engineering analysis by a licensed engineer or registered architect.

TABLE OF CONTENTS	
SHEET #	DESCRIPTION
1	Typical elevation, design pressures & general notes
2	Door panel details
3	Sidelite panel details
4	Horizontal cross sections
5	Vertical cross sections
6	Vertical cross sections
7	Buck & frame anchoring - 2X buck masonry construction
8	Frame anchoring - 1X buck masonry construction
9	Bill of materials, glazing detail & components

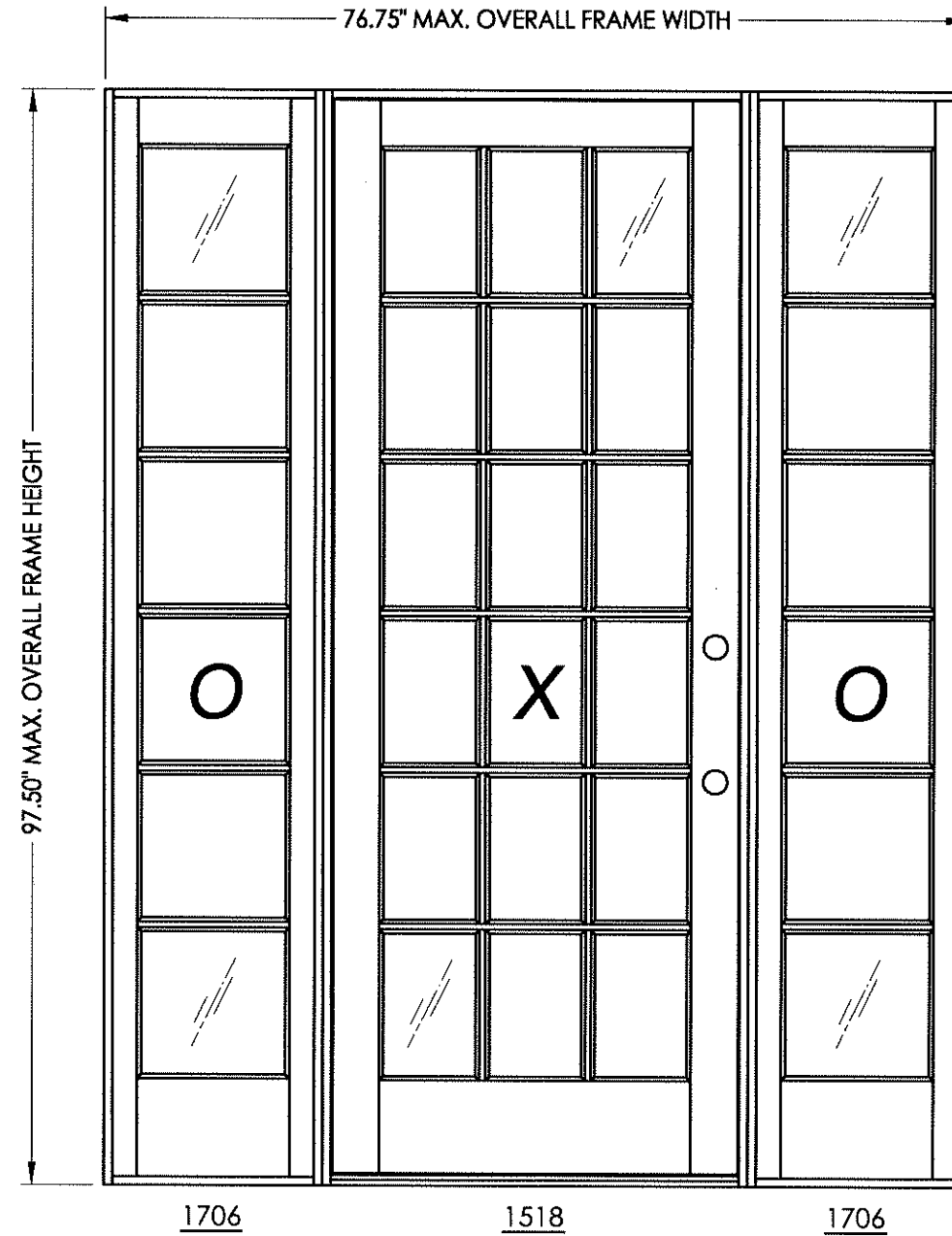

TRUE DIVIDED LITE SHOWN
(1501 / 1701 FULL LITE ALSO APPROVED)

SERIES	OVERALL FRAME DIMENSION	DOOR D.L.O. DIMENSION	SIDELITE D.L.O. DIMENSION	GLASS TYPE	DESIGN PRESSURE (PSF)	
					POSITIVE	NEGATIVE
1501/1701 FULL LITE	76.75" x 97.50"	27.00" x 81.38"	13.25" x 81.38"	G1	+47.0	-47.0
1518/1706 TRUE DIVIDED LITE	76.75" x 97.50"	8.17" x 12.52"	12.88" x 12.52"		+47.0	-47.0

Documents Prepared By:
RW BUILDING CONSULTANTS, INC.
P.O. Box 230 Valrico FL 33595
Phone No.: 813.659.9197
Florida Board of Professional Engineers
Certificate Of Authorization No. 9813
LFS 10.25.12
Lyndon F. Schmidt, P.E. No. 43409

PRODUCT:
ROGUE VALLEY DOOR
GLAZED WOOD DOOR

PART OR ASSEMBLY:
TYPICAL ELEVATION, DESIGN PRESSURES & GENERAL NOTES

NO.	DATE	BY	REVISIONS

DATE: 10/25/12
SCALE: N.T.S.
DWG. BY: AL
CHK. BY: LFS
DRAWING NO.: FL-13137.8
SHEET 1 OF 9

R:\A - Projects\Project Folders\proj 1401-1500\PF 1482\D. RWBC Drawings\FL-13137.6-.10\FL-13137.6-.10.dwg, FL-13137.8

© 2012 R.W. BUILDING CONSULTANTS INC.

R:\A - Projects\Project Folders\proj_1401-1500\PF 1482\D. RWBC Drawings\FL-13137.6-10\FL-13137.6-10.dwg, 3-2

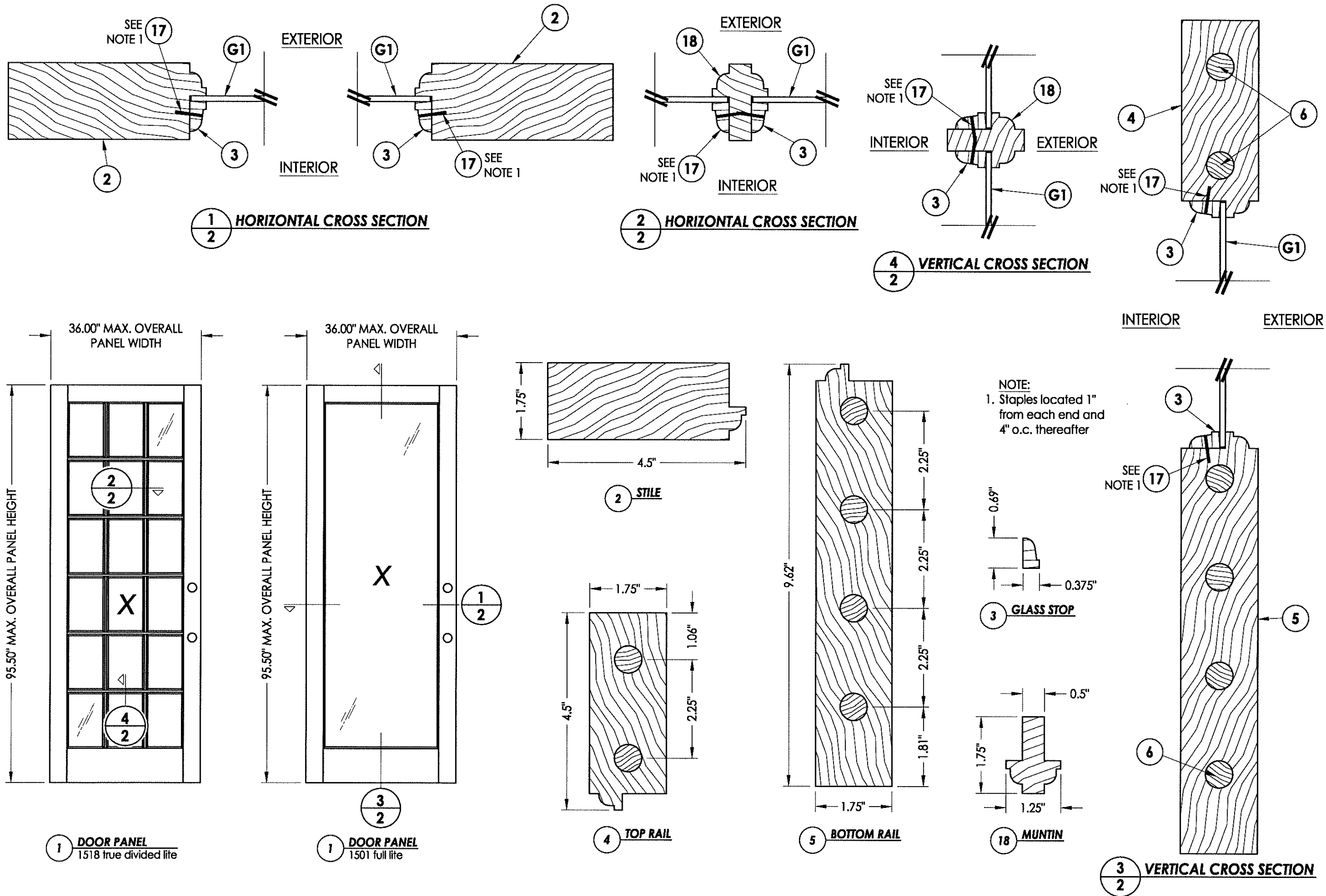

1 DOOR PANEL
1518 true divided lite

1 DOOR PANEL
1501 full lite

4 TOP RAIL

5 BOTTOM RAIL

18 MUNTIN

3 VERTICAL CROSS SECTION
2

Documents Prepared By:
RW BUILDING CONSULTANTS, INC.
 P.O. Box 230 Valrico FL 33595
 Phone No.: 813.659.9197
 Florida Board of Professional Engineers
 Certificate Of Authorization No. 9813
LFS 10.25.12
 Lyndon F. Schmidt, P.E. No. 43409

PRODUCT:
 ROGUE VALLEY DOOR
 GLAZED WOOD DOOR
 PART OR ASSEMBLY:
 DOOR PANEL DETAILS

NO.	DATE	BY

DATE: 10/25/12
 SCALE: N.T.S.
 DWG. BY: AL
 CHK. BY: LFS
 DRAWING NO.: FL-13137.8
 SHEET 2 OF 9

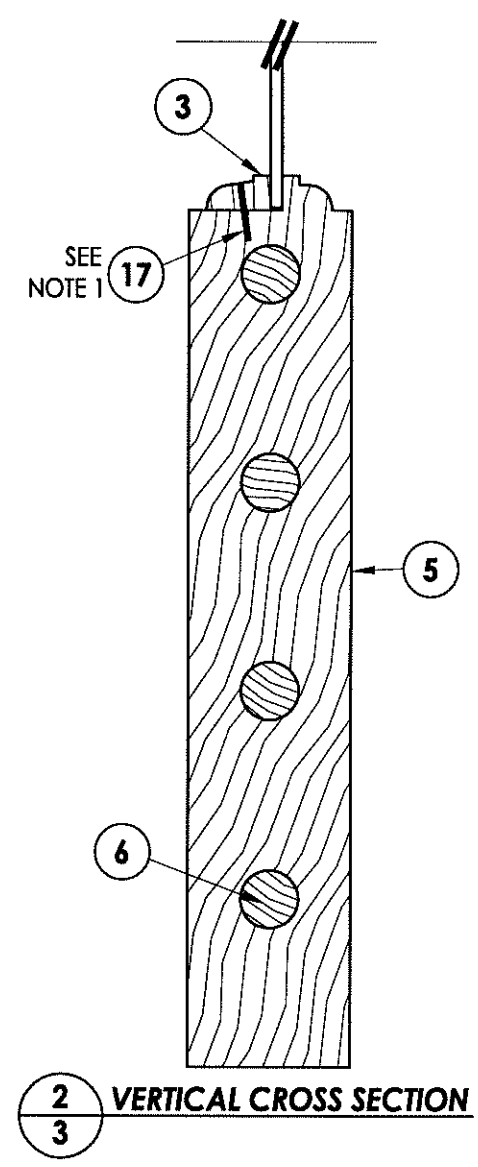
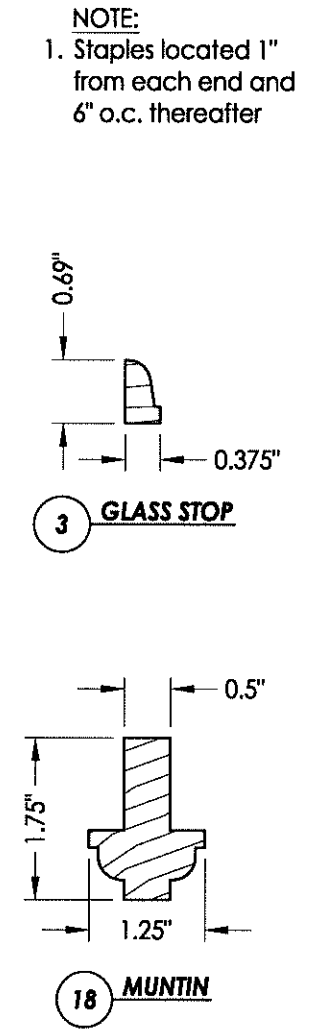
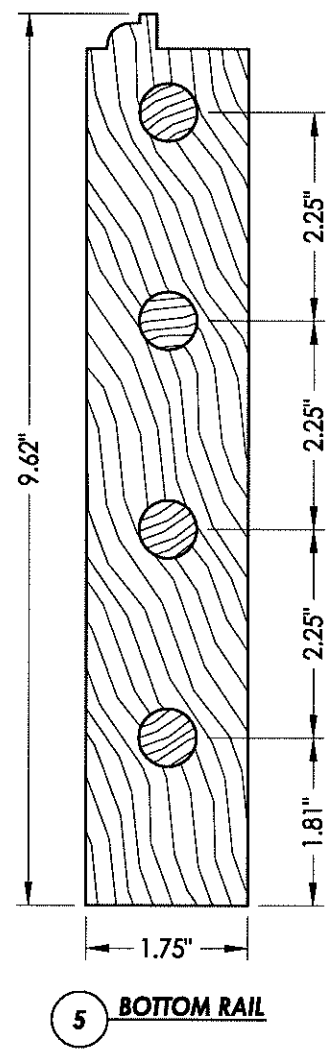
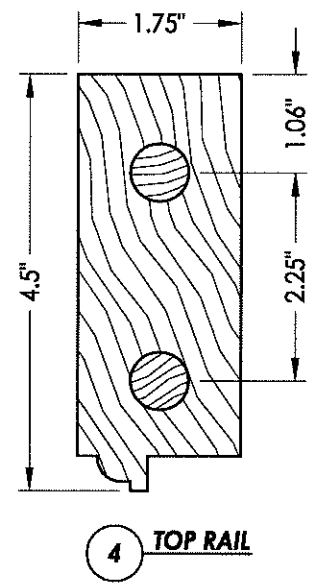
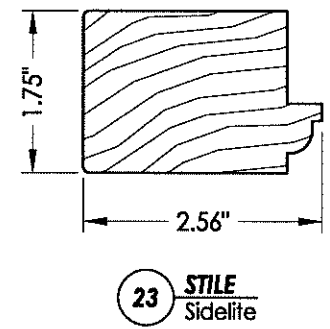
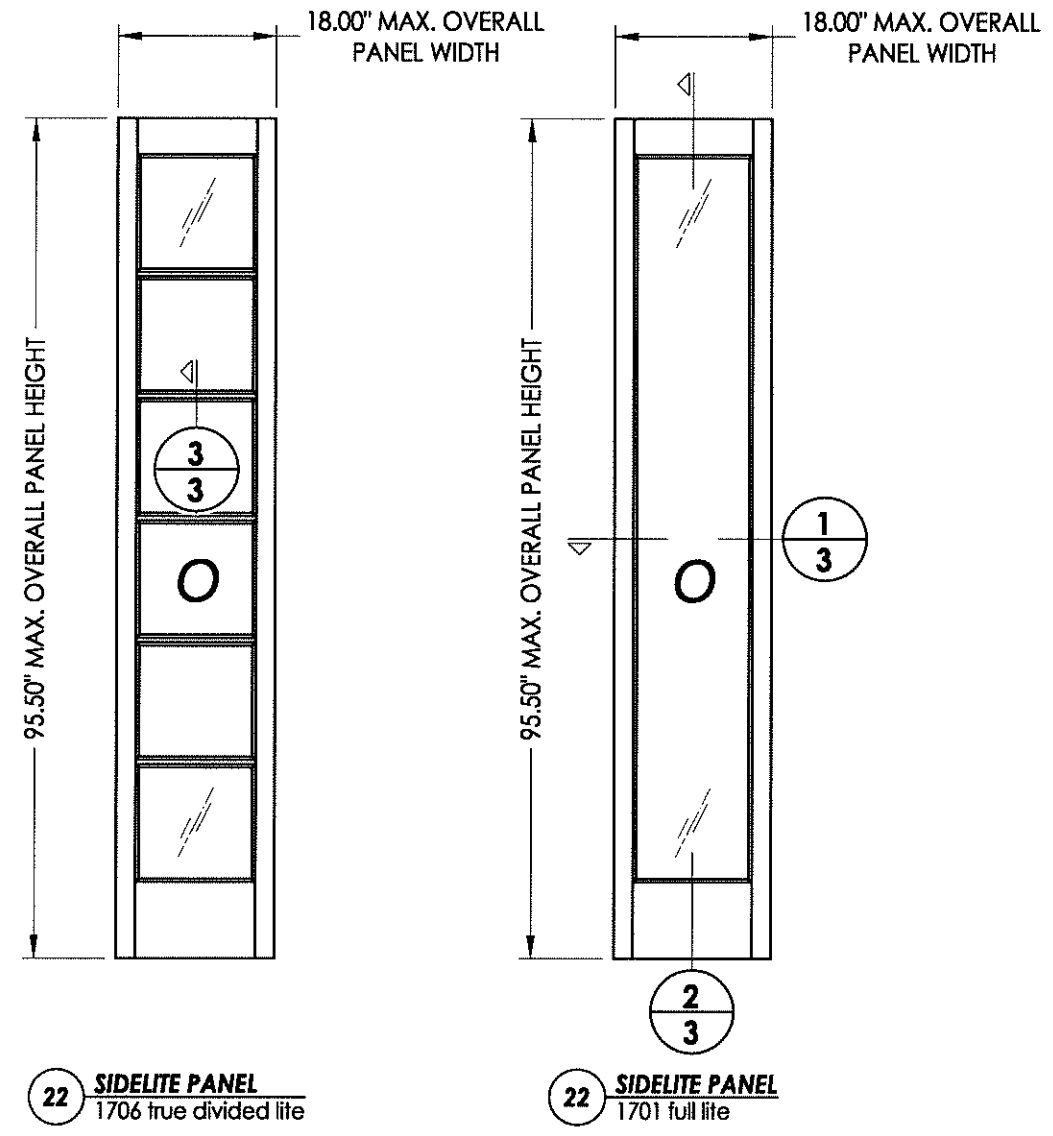
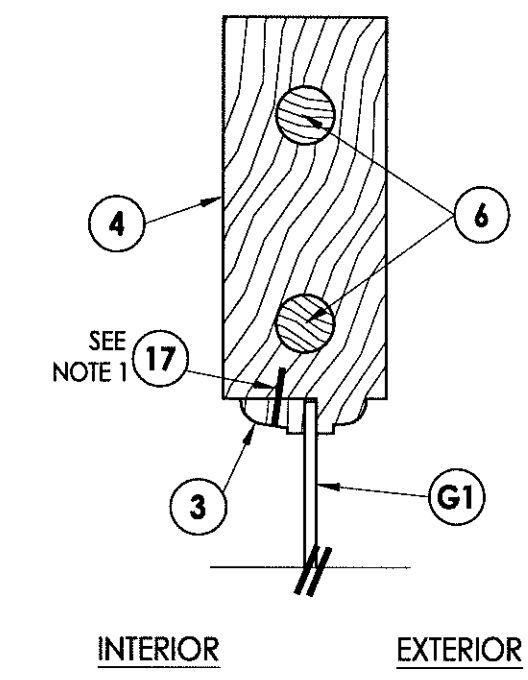
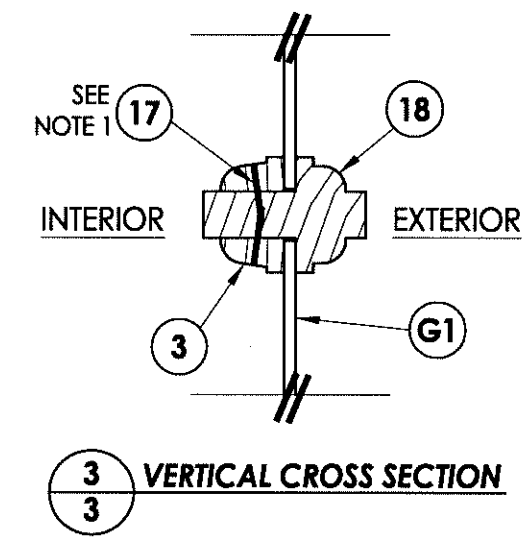
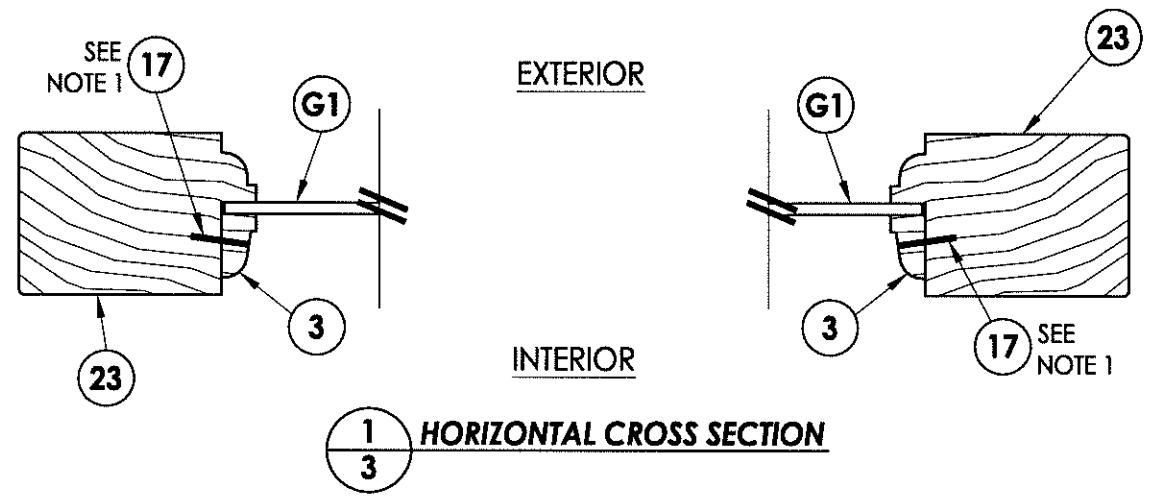

Documents Prepared By:
RW BUILDING CONSULTANTS, INC.
 P.O. Box 230 Valrico FL 33595
 Phone No.: 813.659.9197
 Florida Board of Professional Engineers
 Certificate Of Authorization No. 9813
LFS
 Lyndon F. Schmidt, P.E. No. 43409

PRODUCT: ROGUE VALLEY DOOR
GLAZED WOOD DOOR

PART OR ASSEMBLY: SIDELITE PANEL DETAILS

NO.	DATE	BY	REVISIONS

DATE: 10/25/12
 SCALE: N.T.S.
 DWG. BY: AL
 CHK. BY: LFS
 DRAWING NO.: FL-13137.8
 SHEET 3 OF 9

© 2012 R.W. BUILDING CONSULTANTS INC.

R:\A - Projects\Project Folders\proj_1401-1500\PF 1482\D. RWBC Drawings\FL-13137.6-10\FL-13137.6-10.dwg, 3-4

NOTE:

1. Attach sidelite panel to the frame with screws (#10 X 2-1/2" pfh) 2" from each end and 9" o.c.

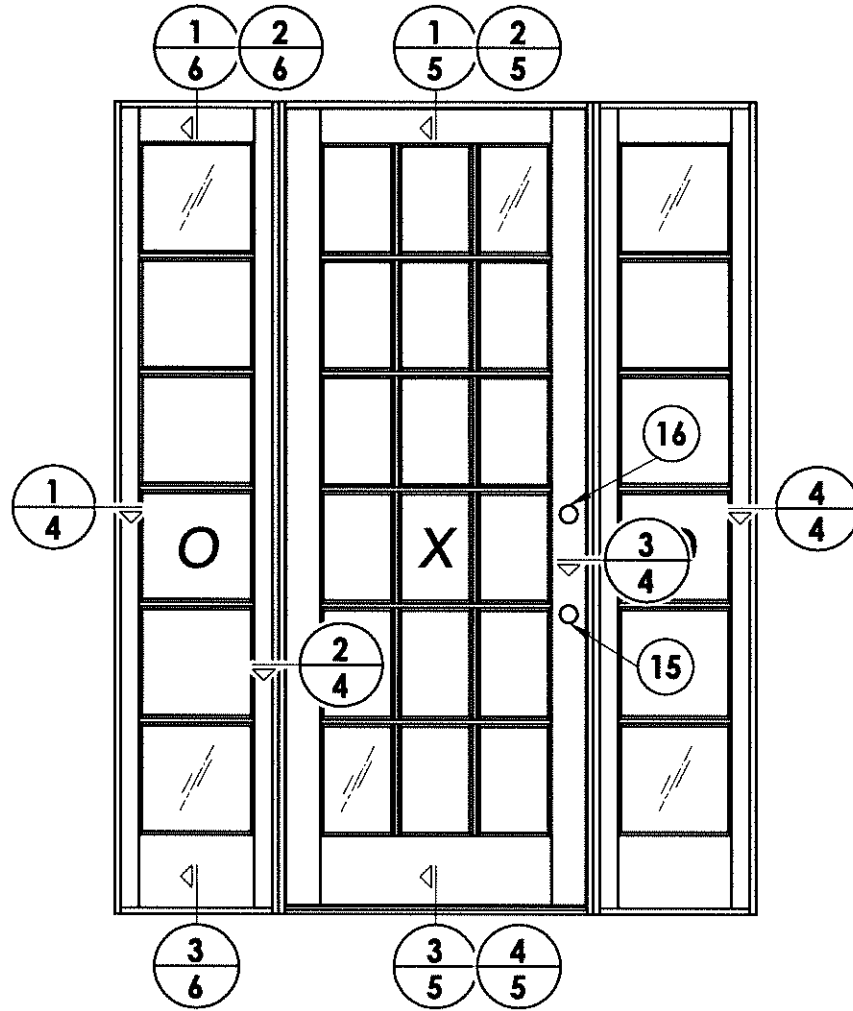

EXTERIOR

INTERIOR

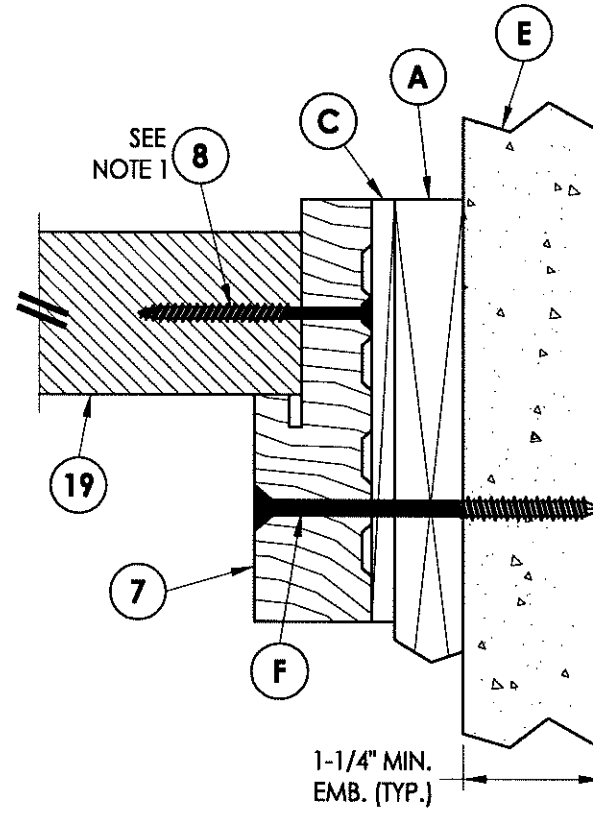

4 HORIZONTAL CROSS SECTION
4 Shown w/ 1X sub-buck

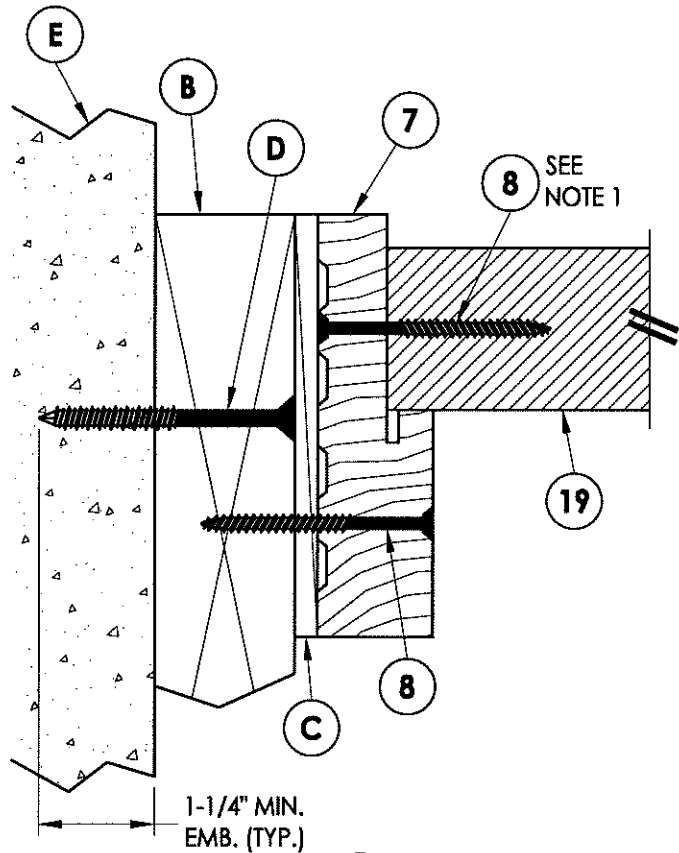

1 HORIZONTAL CROSS SECTION
4 Outswing shown - inswing also approved

EXTERIOR

INTERIOR

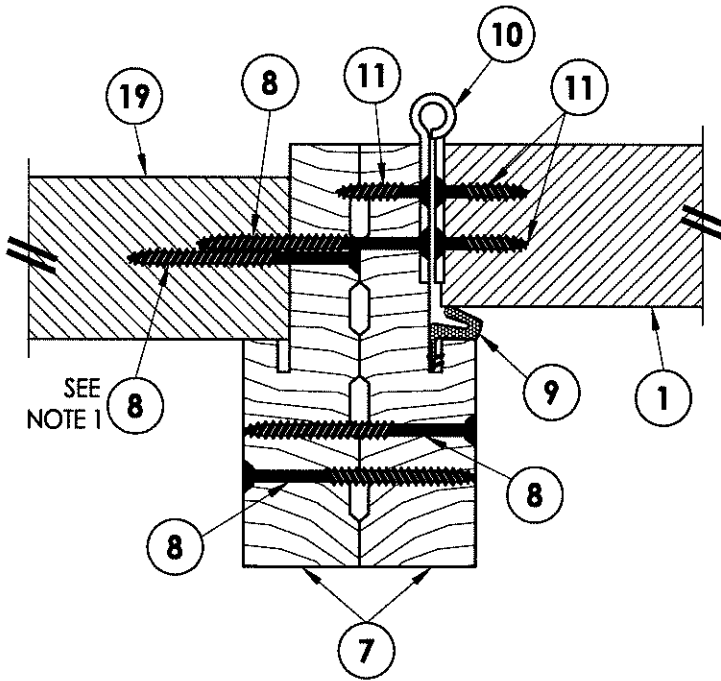

2 HORIZONTAL CROSS SECTION
4 Outswing shown - inswing also approved

EXTERIOR

INTERIOR

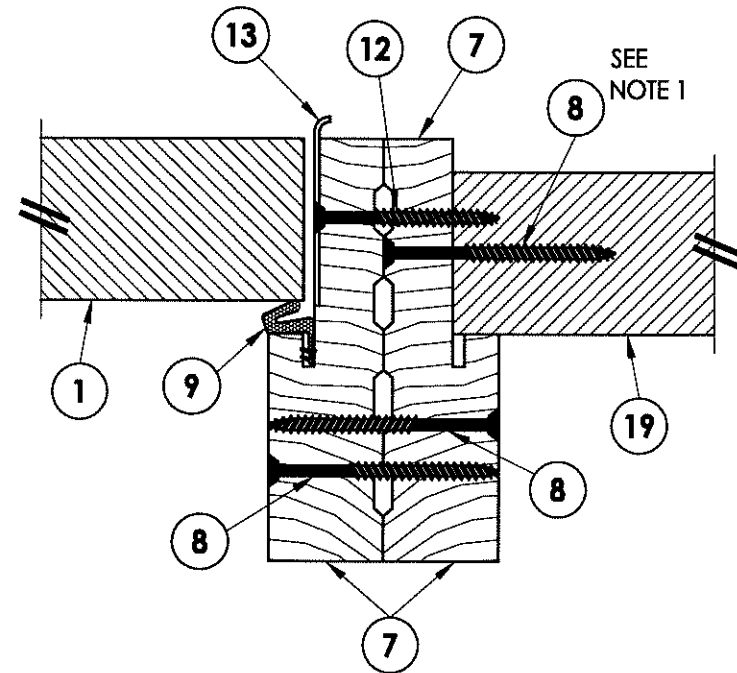

3 HORIZONTAL CROSS SECTION
4 Outswing shown - inswing also approved

Documents Prepared By:

RW BUILDING CONSULTANTS, INC.
P.O. Box 230 Vairico FL 33595
Phone No.: 813.659.9197
Florida Board of Professional Engineers
Certificate of Authorization No. 9813
LFS 10-25-12
Lyndon F. Schmidt, P.E. No. 43409

PRODUCT:
ROGUE VALLEY DOOR
GLAZED WOOD DOOR

PART OR ASSEMBLY:
HORIZONTAL CROSS SECTIONS

NO.	DATE	BY

DATE: 10/25/12

SCALE: N.T.S.

DWG. BY: AL

CHK. BY: LFS

DRAWING NO.:

FL-13137.8

SHEET 4 OF 9

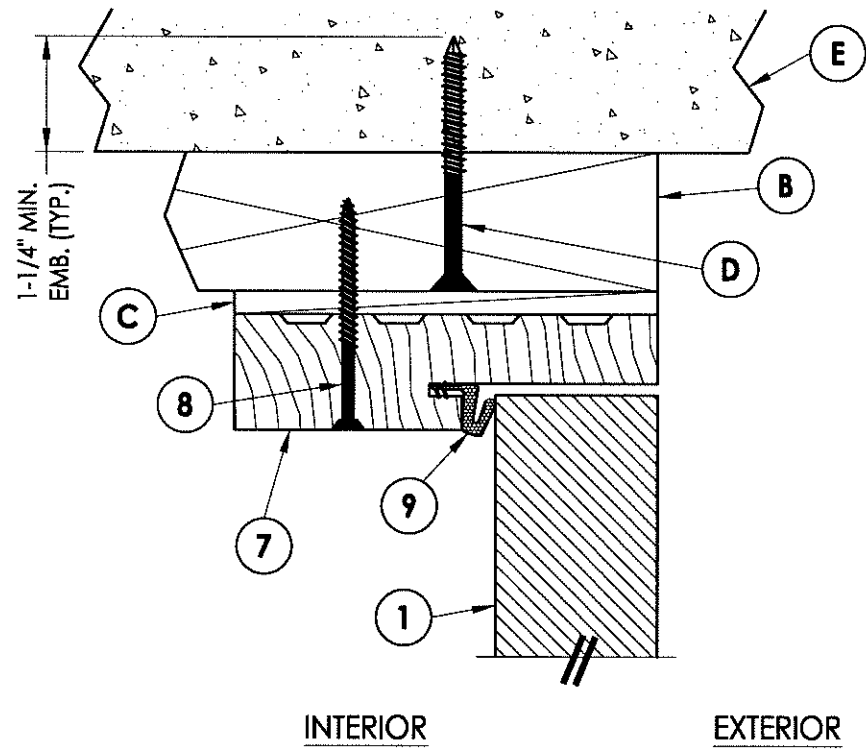

1 VERTICAL CROSS SECTION
5 Outswing shown - inswing also approved

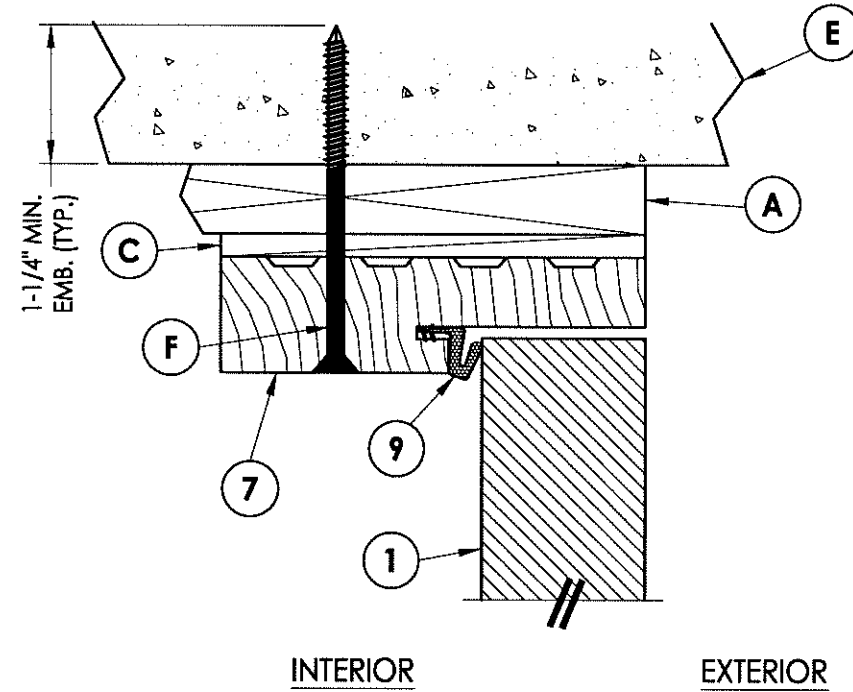

2 VERTICAL CROSS SECTION
5 Shown w/ 1X sub-buck

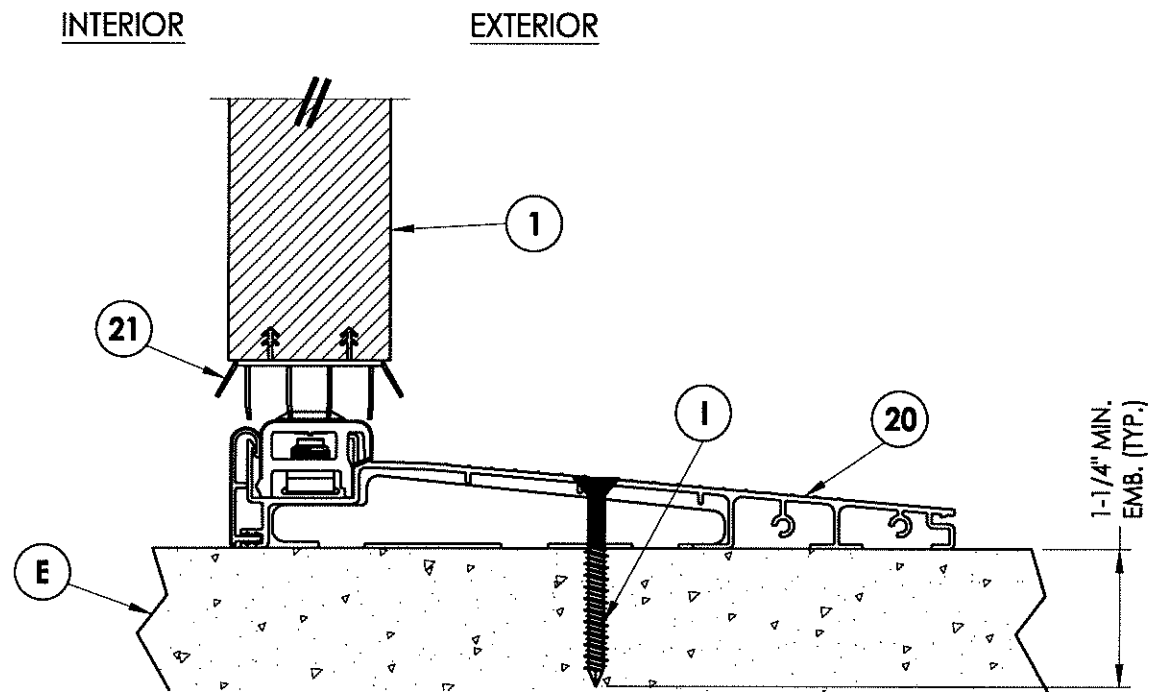

3 VERTICAL CROSS SECTION
5 Inswing threshold

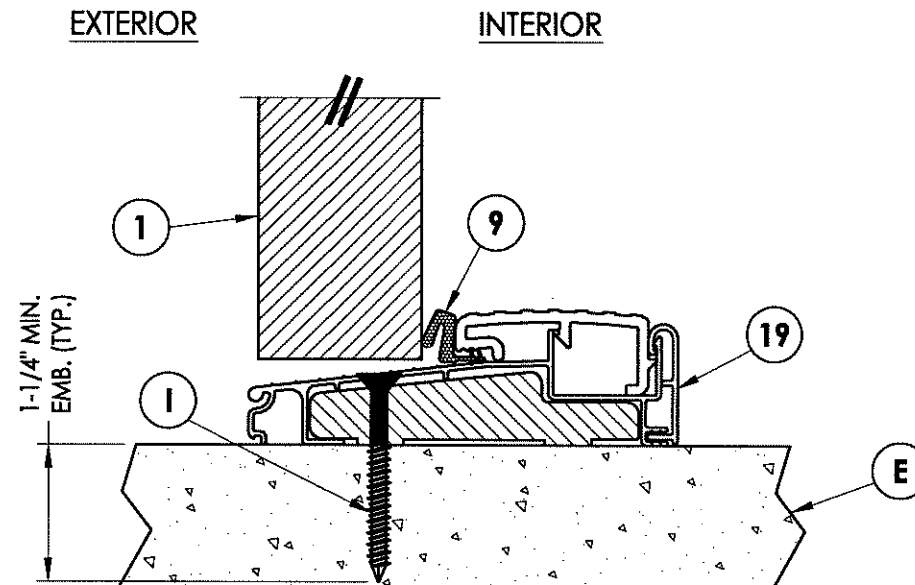

4 VERTICAL CROSS SECTION
5 Outswing threshold

Documents Prepared By:

RW BUILDING CONSULTANTS, INC.
 P.O. Box 230 Valrico FL 33595
 Phone No.: 813.659.9197
 Florida Board of Professional Engineers
 Certificate of Authorization No. 9813
10-25-12
 Lyndon F. Schmidt, P.E. No. 43409

PRODUCT: ROGUE VALLEY DOOR
 GLAZED WOOD DOOR
 PART OR ASSEMBLY: VERTICAL CROSS SECTIONS

NO.	DATE	BY	REVISIONS

DATE: 10/25/12
 SCALE: N.T.S.
 DWG. BY: AL
 CHK. BY: LFS
 DRAWING NO.: FL-13137.8
 SHEET 5 OF 9

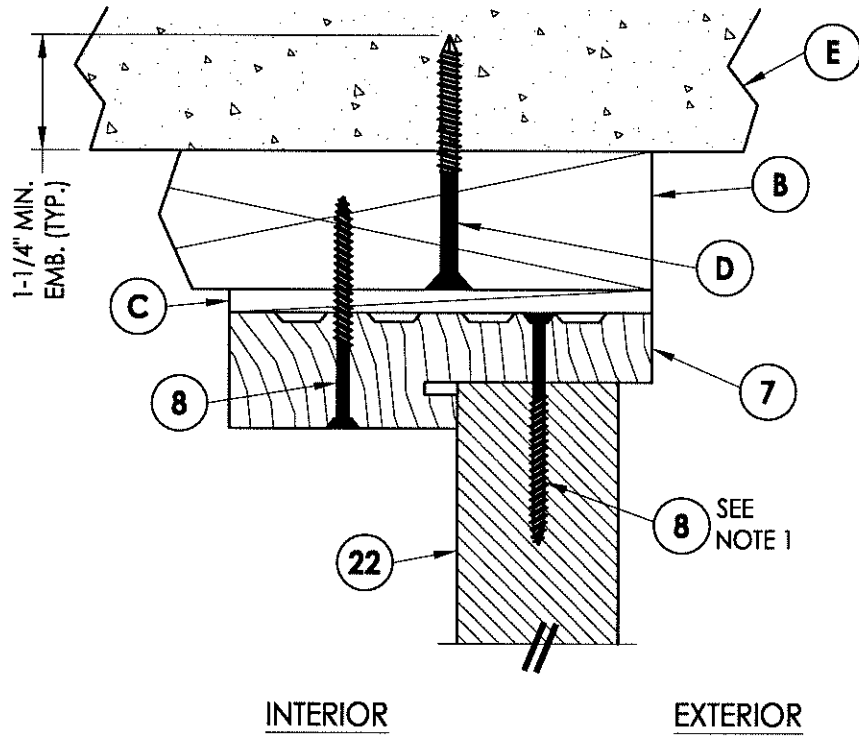

1 **VERTICAL CROSS SECTION**
6 Outswing shown - inswing also approved

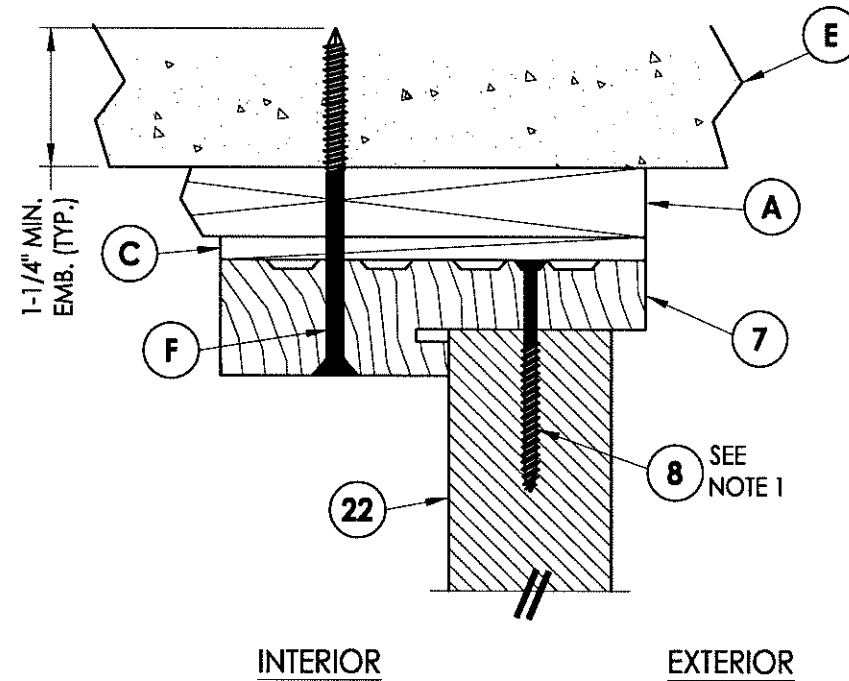

2 **VERTICAL CROSS SECTION**
6 Shown w/ 1X sub-buck

NOTE:
 1. Attach sidelite panel to the frame with screws (#10 X 2-1/2" pfh) 2" from each end and 9" o.c.

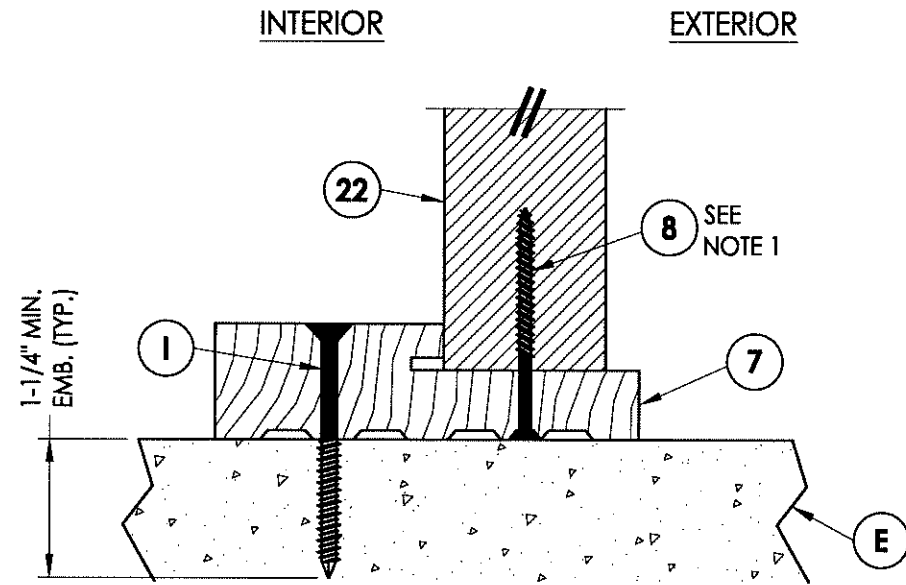

3 **VERTICAL CROSS SECTION**
6 Outswing shown - inswing also approved

Documents Prepared By:
RW BUILDING CONSULTANTS, INC.
 P.O. Box 230 Valrico FL 33595
 Phone No.: 813.659.9187
 Florida Board of Professional Engineers
 Certificate Of Authorization No. 9813
 07-PL-10-25-12
 Lyndon F. Schmidt, P.E. No. 43409

PRODUCT:
 ROGUE VALLEY DOOR
 GLAZED WOOD DOOR

PART OR ASSEMBLY:
 VERTICAL CROSS SECTIONS

NO.	DATE	BY	REVISIONS

DATE: 10/25/12
 SCALE: N.T.S.
 DWG. BY: AL
 CHK. BY: LFS
 DRAWING NO.: FL-13137.8
 SHEET 6 OF 9

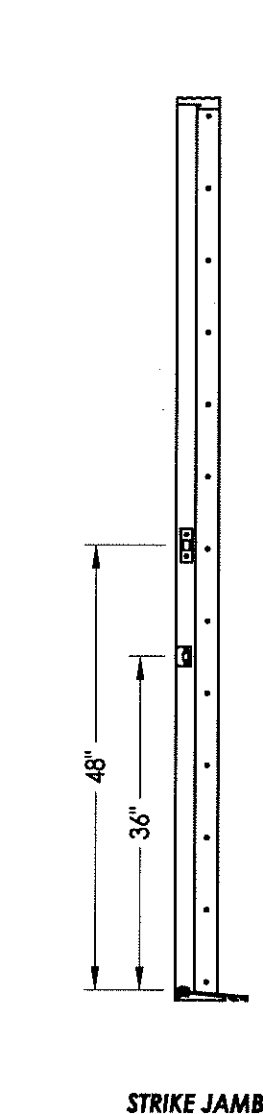
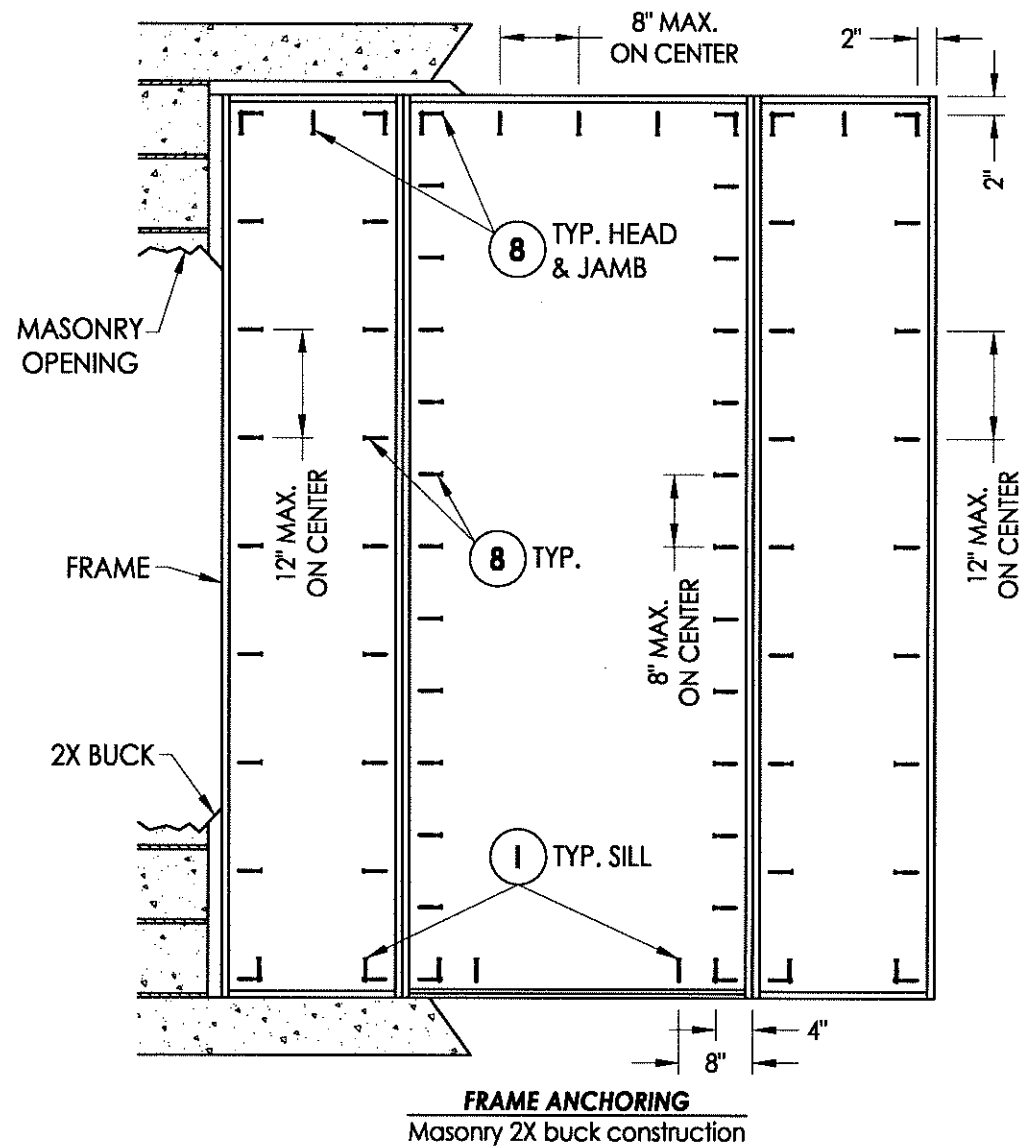
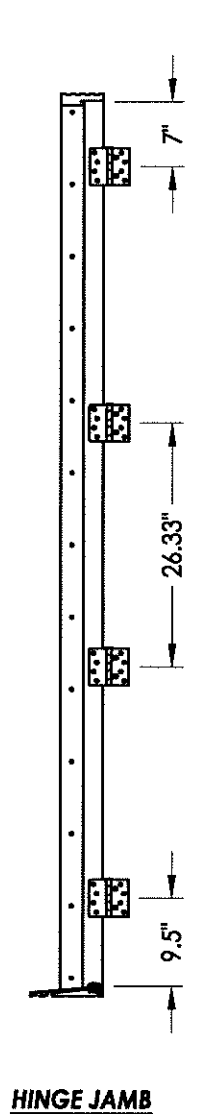
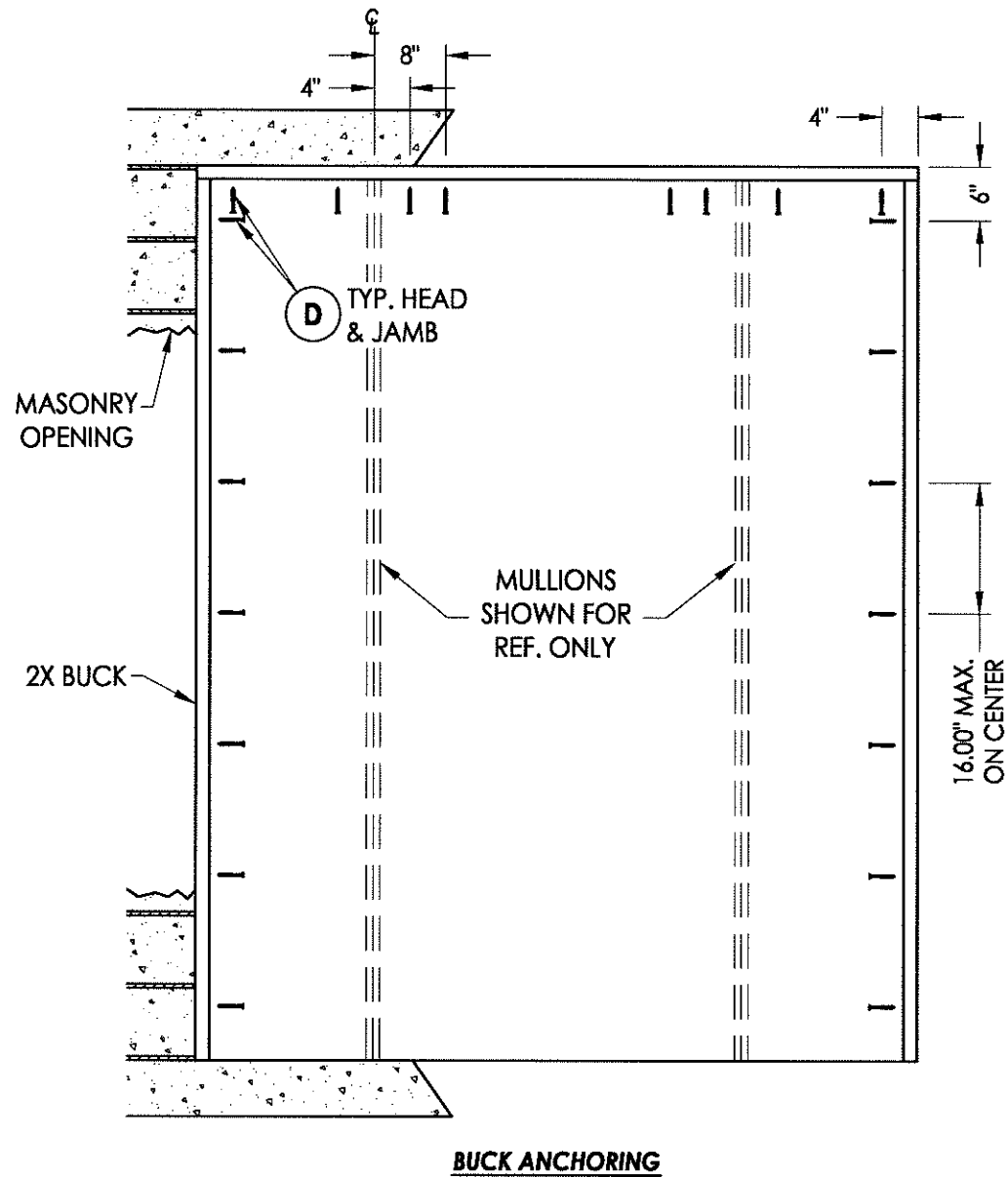

CONCRETE ANCHOR NOTES:

1. Substitution of equal concrete screws from a different supplier may have different edge distance and center distance requirements.
2. Concrete screw locations at the corners may be adjusted to maintain the minimum edge distance to mortar joints. If concrete screw locations noted as "MAX. ON CENTER" must be adjusted to maintain the minimum edge distance to mortar joints, additional concrete screws may be required to ensure the maximum on center dimension is not exceeded.
3. Concrete anchor table:

ANCHOR TYPE	ANCHOR SIZE	MINIMUM EMBEDMENT	MINIMUM CLEARANCE TO MASONRY EDGE	MINIMUM CLEARANCE TO ADJACENT ANCHOR
ITW	1/4"	1-1/4"	2-1/2"	3"
ELCO	1/4"	1-1/4"	1"	4"

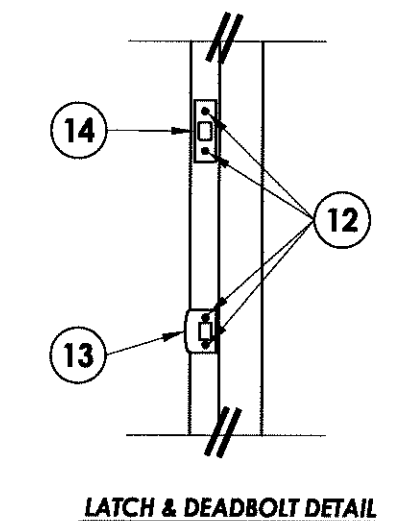
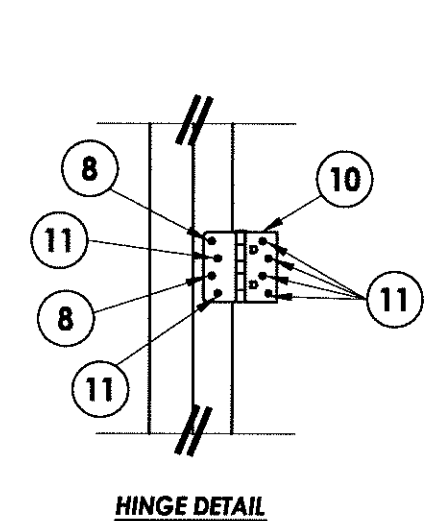

Documents Prepared By:
RW BUILDING CONSULTANTS, INC.
 P.O. Box 230 Valrico FL 33595
 Phone No.: 813.659.9197
 Florida Board of Professional Engineers
 Certificate of Authorization No. 9813
 17-504 10-25-12
 Lyndon F. Schmidt, P.E. No. 43409

PRODUCT:
 ROGUE VALLEY DOOR
 GLAZED WOOD DOOR

PART OR ASSEMBLY:
 BUCK & FRAME ANCHORING 2X
 BUCK MASONRY CONSTRUCTION

NO.	DATE	BY	REVISIONS

DATE: 10/25/12
 SCALE: N.T.S.
 DWG. BY: AL
 CHK. BY: LFS
 DRAWING NO.: FL-13137.8
 SHEET 7 OF 9

© 2012 R.W. BUILDING CONSULTANTS INC.

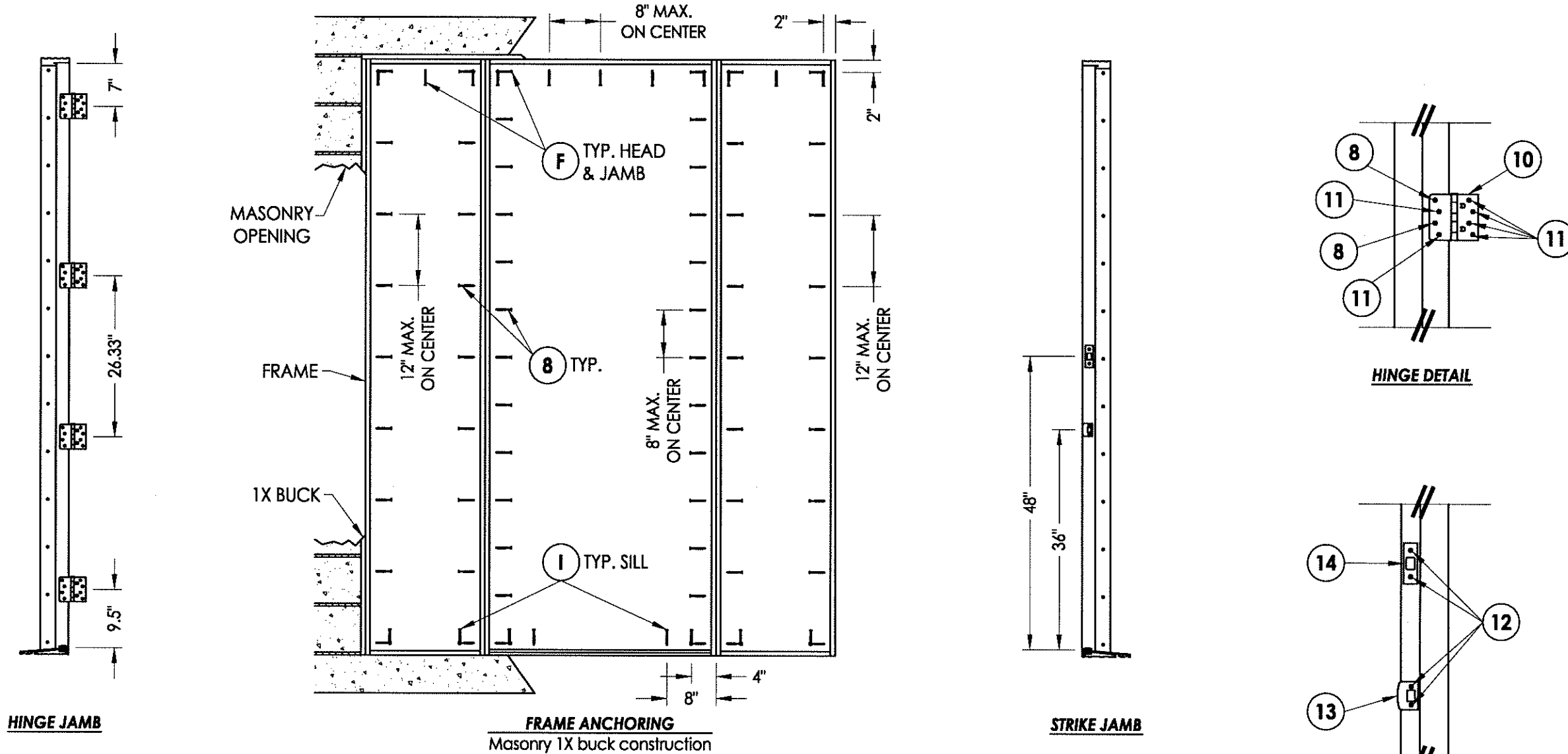

CONCRETE ANCHOR NOTES:

1. Substitution of equal concrete screws from a different supplier may have different edge distance and center distance requirements.
2. Concrete screw locations at the corners may be adjusted to maintain the minimum edge distance to mortar joints. If concrete screw locations noted as "MAX. ON CENTER" must be adjusted to maintain the minimum edge distance to mortar joints, additional concrete screws may be required to ensure the maximum on center dimension is not exceeded.
3. Concrete anchor table:

ANCHOR TYPE	ANCHOR SIZE	MINIMUM EMBEDMENT	MINIMUM CLEARANCE TO MASONRY EDGE	MINIMUM CLEARANCE TO ADJACENT ANCHOR
ITW	1/4"	1-1/4"	2-1/2"	3"
ELCO	1/4"	1-1/4"	1"	4"

Documents Prepared By:
RW BUILDING CONSULTANTS, INC.
 P.O. Box 230 Valrico FL 33595
 Phone No.: 813.659.9197
 Florida Board of Professional Engineers
 Certificate Of Authorization No. 9813
 Lyndon F. Schmidt, P.E. No. 43409

PRODUCT:
 ROGUE VALLEY DOOR
 GLAZED WOOD DOOR

PART OR ASSEMBLY:
 FRAME ANCHORING 1X BUCK
 MASONRY CONSTRUCTION

NO.	DATE	BY	REVISIONS

DATE: 10/25/12
 SCALE: N.T.S.
 DWG. BY: AL
 CHK. BY: LFS
 DRAWING NO.: FL-13137.8
 SHEET 8 of 9

R:\A - Projects\Project Folders\proj 1401-1500\PE 1482\DWG Drawings\FL-13137.6-10\FL-13137.6-10.dwg, 3-9

BILL OF MATERIALS		
ITEM	DESCRIPTION	MATERIAL
A	1X BUCK	WOOD
B	2X BUCK (SG >= 0.55)	WOOD
C	1/4" MAX. SHIM SPACE	-
D	1/4" X 2-3/4" ELCO OR ITW CONCRETE SCREW	STEEL
E	MASONRY - 3,192 PSI MIN. CONCRETE CONFORMING TO ACI 301 OR HOLLOW BLOCK CONFORMING TO ASTM C90	CONCRETE
F	1/4" X 3-3/4" ELCO OR ITW CONCRETE SCREW	STEEL
I	1/4" X 2-1/4" ELCO OR ITW CONCRETE SCREW	STEEL
1	DOOR PANEL - SEE DOOR PANEL DETAIL SHEET FOR DETAILS	-
2	STILE (PINE SG >= 0.35)	WOOD
3	GLASS STOP (PINE SG >= 0.35)	WOOD
4	TOP RAIL (PINE SG >= 0.35)	WOOD
5	BOTTOM RAIL (PINE SG >= 0.35)	WOOD
6	DOWEL	WOOD
7	JAMB (PINE SG >= 0.35)	WOOD
8	#10 X 2-1/2" PFH WOOD SCREW	STEEL
9	WEATHERSTRIP	FOAM
10	HINGE	STEEL
11	#10 X 1" PFH WOOD SCREW	STEEL
12	#10 X 2" PFH WOOD SCREW	STEEL
13	LATCH STRIKE PLATE	STEEL
14	SECURITY STRIKE PLATE	STEEL
15	KWIKSET SERIES LOCKSET (400)	STEEL
16	KWIKSET SERIES DEADBOLT (660)	STEEL
17	22ga. X 3/16" CROWN X 5/8" LONG STAPLE	STEEL
18	MUNTIN (PINE SG >= 0.35)	WOOD
19	THRESHOLD (INSWING)	ALUM.
20	THRESHOLD (OUTSWING)	ALUM.
21	DOOR SWEEP	VINYL
22	SIDELITE PANEL - SEE SIDELITE PANEL DETAIL SHEET FOR DETAILS	-
23	STILE (PINE SG >= 0.35)	WOOD

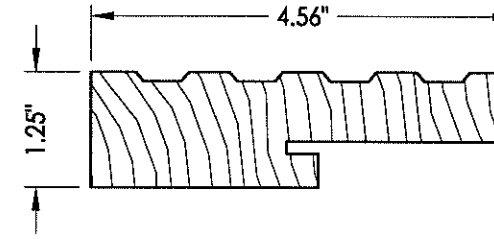

7 HEAD & SIDE Jamb

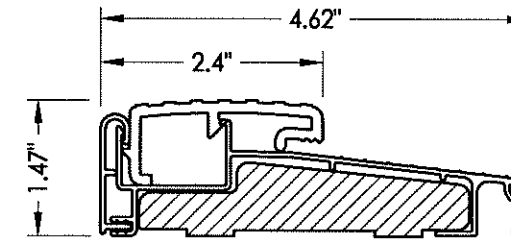

19 THRESHOLD Outswing

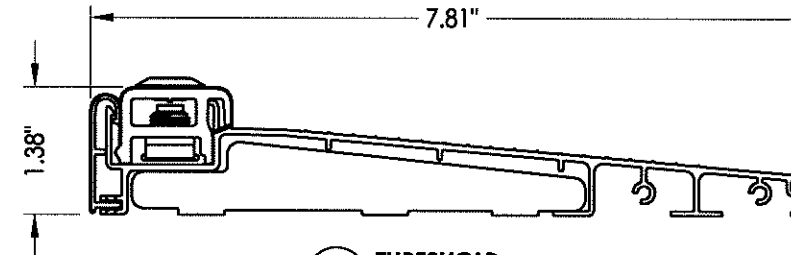

20 THRESHOLD Inswing

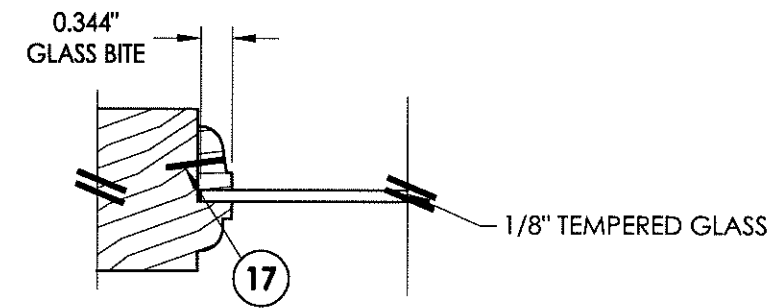

G1 GLAZING DETAIL

Documents Prepared By: **RW** BUILDING CONSULTANTS, INC.
P.O. Box 230 Valrico FL 33595
Phone No.: 813.659.9197
Florida Board of Professional Engineers
Certificate Of Authorization No. 9813
Lyndon F. Schmidt, P.E. No. 43409

PRODUCT: ROGUE VALLEY DOOR
GLAZED WOOD DOOR

PART OR ASSEMBLY: BILL OF MATERIALS, GLAZING
DETAIL & COMPONENTS

NO.	DATE	BY	REVISIONS

DATE: 10/25/12
SCALE: N.T.S.
DWG. BY: AL
CHK. BY: LFS
DRAWING NO.: FL-13137.8
SHEET 9 OF 9

© 2012 R.W. BUILDING CONSULTANTS INC.